

specialty blades, inc.

Specialty Blades: Technology Leader In Custom-Made Cutting Blades

For more than a decade, Specialty Blades, Inc. has pursued a single goal: satisfying its customers by providing the finest quality, custom-made cutting blades available. In the process, we have developed a unique blade manufacturing and sharpening technology which relies on special purpose, computer numerical controlled (CNC) machine tools to fabricate and sharpen custom blades. Our highly skilled, team-based workforce uses this equipment, enhanced by the latest CAD/CAM and DNC technologies, to create custom blades and machine knives that improve your cutting application.

Unlike most blade manufacturers who require you to choose from a catalogue of standard blade shapes, Specialty Blades encourages you to disregard limitations on blade shape, materials and minimum quantity that you may encounter with other blade manufacturers. Call Specialty Blades and let us help you find a solution specifically suited for your needs.

Committed To Customer Satisfaction

Specialty Blades provides customers from many different industries with the finest quality custom-made cutting blades. Throughout its existence, the company has focused on improving technology to enhance the level of edge consistency, sharpness and quality of each blade manufactured. Specialty Blades is committed to continually seeking new methods of manufacturing and sharpening to deliver consistently high quality, competitively priced, made-to-order blades within short lead times.

Total customer satisfaction, whether related to quality, delivery or price, is of utmost importance to every member of Specialty Blades' manufacturing teams. By continually investing in state-of-the-art technology and instilling all of our employees with a commitment to customer satisfaction, we can ensure that you are

providing custom blades for industry

Industries Served

Specialty Blades utilizes the CNC sharpening process to manufacture razor sharp, made-to-order cutting blades and machine knives for many different *industrial applications*, including:

- ♦ Plastic Extrusion
- ♦ Packaging
- ♦ Film Slitting
- ♦ Industrial Food Processing
- ♦ Tire & Automotive Production
- ♦ Plastic Pelletizing
- ♦ Blow Molding & Flash Trimming
- ♦ Computerized Sign Manufacture
- ♦ Fiber & Textile Manufacture
- ♦ Cable Cutting and Stripping
- ♦ Precision Hand Tools
- ♦ And virtually any other industry that utilizes blades

Medical device manufacturers who require a high level of quality and precision sharpness, also benefit from Specialty Blades' manufacturing process. These *medical applications* include arthroscopic, orthopedic, laparoscopic/endoscopic, diagnostic, ophthalmic, plastic, and other surgical procedures.



Specialty Blades, Inc.

phone: 800-252-3371 or 540-248-2200

fax: 800-742-7741 or 540-248-4400

email: sales@specialtyblades.com

www.specialtyblades.com

Mail To:

Specialty Blades, Inc.

PO Box 3166, Staunton, VA 24402

Ship To:

9 Technology Drive, Staunton, VA 24401





Specialty Blades, Inc.

phone: 800-252-3371 or 540-248-2200 † fax: 800-742-7741 or 540-248-4400

email: sales@specialtyblades.com † specialtyblades.com

Pointed Tip Blades

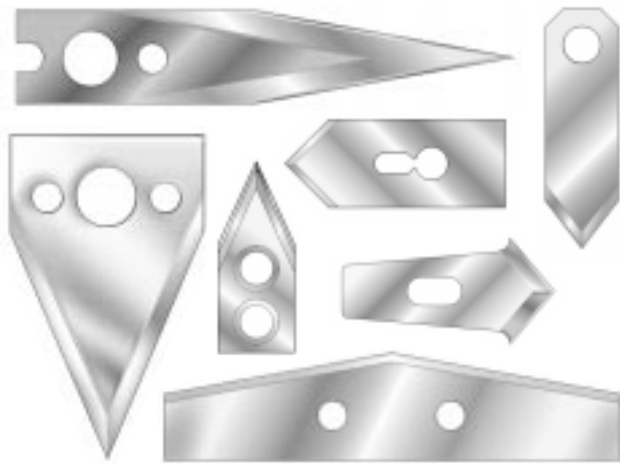

Concave/Hook Blades

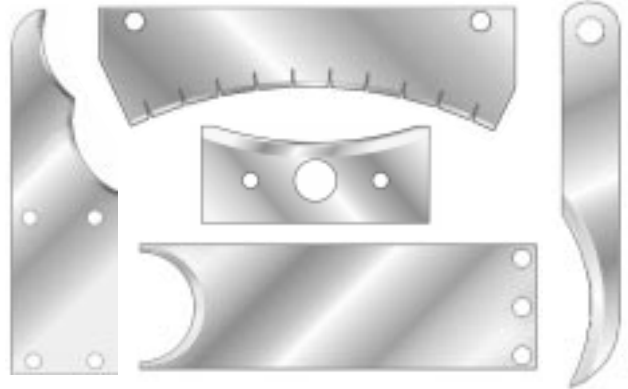

Formed Blades



Multiple-Edged Blades

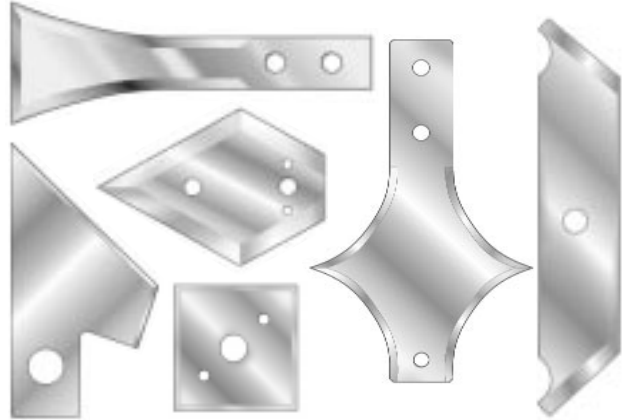

Combination Edge Geometry Blades

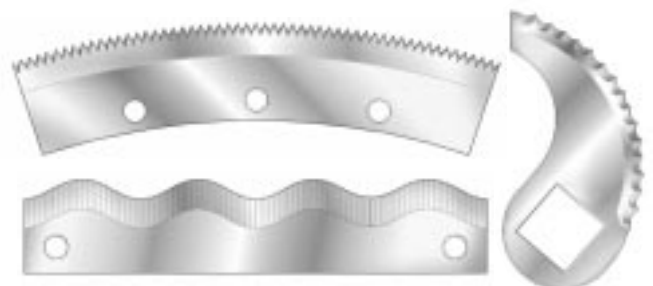

ISO 9002
CERTIFIED COMPANY

Blade Shapes For Every Application

Since most blades are made-to-order, the illustrations shown below may not be to scale and are only a limited representation of Specialty Blades' unique manufacturing capabilities.

Scored Strips

This process is ideally suited for small, thin stainless steel blades since it reduces excessive handling of individual blades and can enhance assembly into cutting devices.

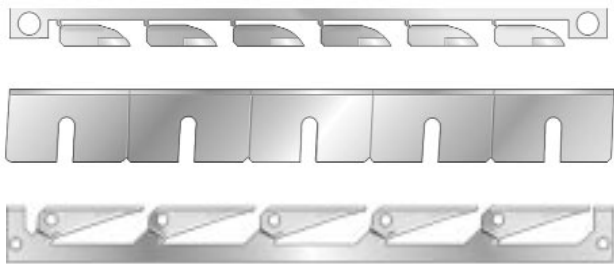

Other Blade Shapes & Edges

Specialty Blades has the capability to produce many unique edge configurations, including wavy-edged, scalloped, v-notched and circular blades.

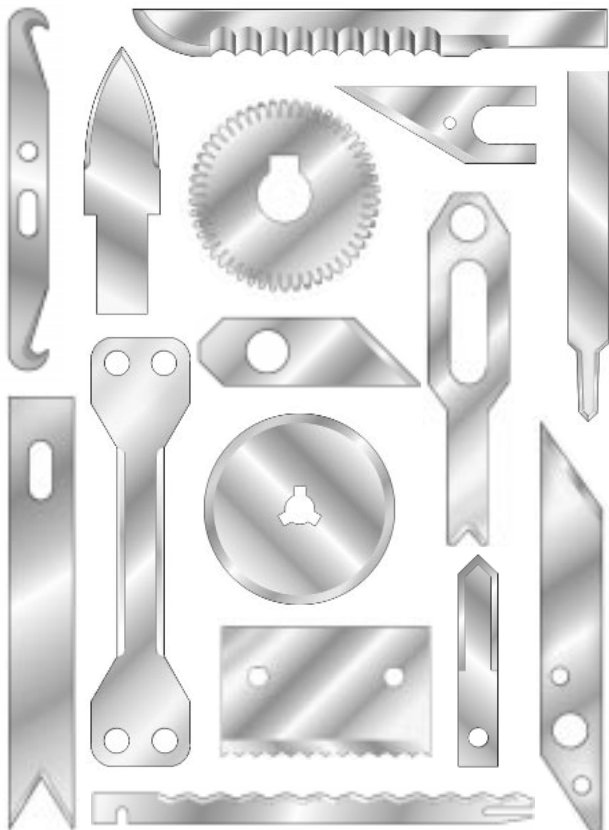

Convex/Curved Blades

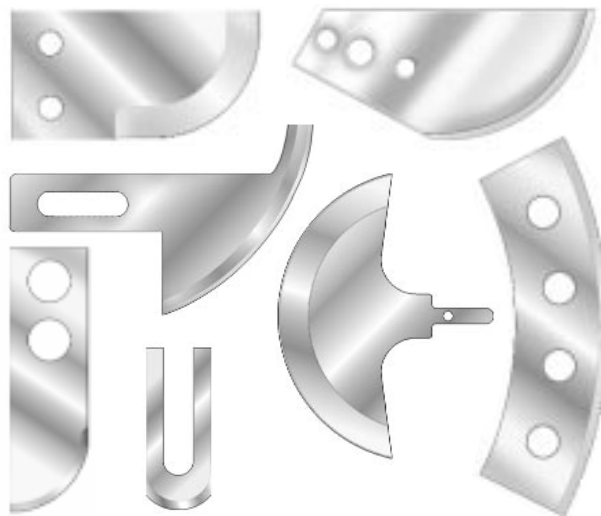

Toothed Blades

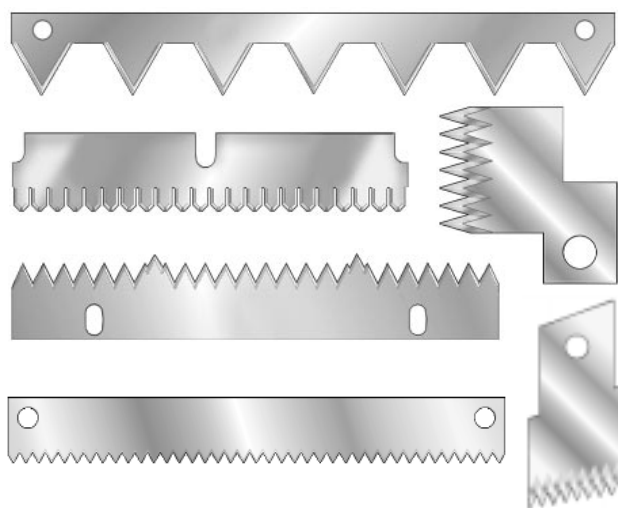

EDGE GEOMETRY OPTIONS

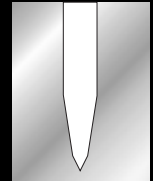

Double Bevel

The most common edge, a Double-Bevel edge can be sharpened to an extremely keen edge. Since the cutting forces are symmetrical to the blade edge, this edge minimizes the tendency for the edge to "roll" or deform.

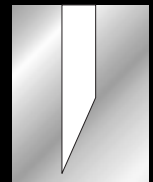

Chisel Edge

A pure Chisel Edge is used when the cut must be co-incident with one side of the blade, or when a "shearing" action is required.

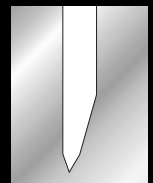

Modified Chisel

Similar to a Chisel Edge, but with an added secondary hone facet at the blade tip. This geometry provides the sharpness of the Double-Bevel edge, while giving an off-center cut.

ZIRCONIA CERAMIC BLADES

And because they last up to 100 times longer than conventional steel blades, you can spend more time slitting product and less time changing blades.

Zirconia's extreme hardness (Rc 75), combined with its superior resistance to corrosion and abrasion, is the major contributing factor to outstanding blade life and performance. The inherent physical properties and submicron grain structure of HIP zirconia produce an extremely smooth cutting surface that has a very low coefficient of friction, ensuring that film edges are not stretched during slitting.

Specialty Blades' advanced technology enables us to manufacture the sharpest zirconia edges in the world.

Don't settle for blades that dull quickly and require frequent replacement. For state-of-the-art performance, you can't beat zirconia ceramic



For film slitting applications as well as applications involving paper and foil, you can't beat the performance of zirconia ceramic razor blades. Hot isostatic pressed (HIP) zirconia ceramic blades are extremely hard, sharp, and wear resistant, producing precision cuts and better looking slit edges time after time.



Specialty Blades, Inc.

phone: 800-252-3371 or 540-248-2200

fax: 800-742-7741 or 540-248-4400

email: sales@specialtyblades.com

www.specialtyblades.com



MATERIAL OPTIONS

1095 Carbon Steel

Available in either Rc 50 spring temper or custom hardened and tempered up to Rc 62, AISI 1095 is an economical material choice where corrosion is not expected to be a problem.

Heat-Treated Stainless Steels

Suitable for industrial and medical applications, these 400 series martensitic steels are much more corrosion-resistant than carbon steels and can be sharpened to equally-keen edge sharpness. Specialty Blades maintains an extensive inventory of Razor Blade Stainless in thicknesses from .010"-.062" thick, as well as 420 "Cutlery Grade" Stainless.

301 Stainless, 17-4 & 17-7 PH Stainless

These austenitic stainless steels provide more corrosion and shock resistance than 400 series martensitic steels, but sacrifice some wear resistance and hardness.

High-Speed Steels

High-speed steels offer high wear resistance. M-2 provides up to six times more wear than conventional blade steel, while M-4 is three times more durable than M-2. High-speed steels also have excellent temper resistance, holding their hardness even when exposed to temperatures up to 1,000° F.

Tool Steels

This family of steels offers a wide array of material choices not available from producers of strip-sharpened blades. Choose the high wear of D-2, the shock resistance of S-7, the corrosion resistance of ATS 34, the balanced wear/toughness properties of A-2, or give us a call for even more options.

Extreme-Wear Tool Steels

With blade life up to 25 times greater than conventional blade steel, A-7, A-11 and extra wear tool steels offer superior wear resistance to other steels and are more shock resistant than carbide or ceramic.

High-Performance Zirconia Ceramic

Recent developments have made it possible to produce extremely sharp blades from transformation-toughened zirconia. Although not recommended for high-shock applications, the Rc 75 hardness and low friction coefficient make zirconia particularly effective in film slitting operations, where blade life can be more than 100 times that of conventional steel.

Tungsten Carbide

Carbide with submicron grain size can be sharpened to a razor edge without the inherent brittleness frequently associated with conventional carbide. Although not as shock-resistant as steel, carbide is extremely wear resistant. If chipping and breakage can be avoided, blade life will typically be 50+ times that of conventional blade steels.

Coatings

With many materials, desirable qualities can be enhanced by applying wear resistant TiN, TiC, and TiCN coatings or dry film lubricant coatings such as Teflon®.

There is no single blade material that's appropriate for all applications, so Specialty Blades offers a wide range of materials from which to choose.

We advise customers to **"Optimize-not compromise"** when selecting a blade material to ensure the right mix of properties for each individual application.

The more commonly-used blade materials are briefly discussed here.

For more detailed information, please refer to the Technical Information section of our website at www.specialtyblades.com.



Specialty Blades, Inc.

phone: 800-252-3371 or 540-248-2200

fax: 800-742-7741 or 540-248-4400

email: sales@specialtyblades.com

www.specialtyblades.com

ISO 9002
CERTIFIED COMPANY

Prototyping Services

Throughout the initial design stage, Specialty Blades works closely with its customers to produce blades that meet their unique cutting requirements. Our knowledgeable sales staff can assist you in the selection of blade materials and cutting edge configurations optimized for your application.

In-house laser cutting equipment and a wide variety of steels in inventory allow Specialty Blades to manufacture prototype blades quickly, often in a matter of days or weeks, instead of months. Additionally, our manufacturing and sharpening process is well-suited to accommodate prototyping variations of blade shape, materials, and sharpened edge geometries, to assist you in determining the best blade for your application prior to going into production.

If you have a new blade design you'd like to try, or if you want to improve the cutting performance of the blades you've been using for years, give Specialty Blades a call today.



Specialty Blades, Inc.

phone: 800-252-3371 or 540-248-2200

fax: 800-742-7741 or 540-248-4400

email: sales@specialtyblades.com

www.specialtyblades.com

Mail To:

Specialty Blades, Inc.

PO Box 3166, Staunton, VA 24402

Ship To:

9 Technology Drive, Staunton, VA 24401



Computer-Based Manufacturing Technology

To address the cutting blade needs of industry and original equipment manufacturers, Specialty Blades has developed an innovative sharpening process which produces razor sharp, custom-made blades and knives for a wide variety of industrial and medical applications.

Conventional razor blade technology depends upon processing a continuous strip of steel, separating it into individual blades only after the stamping, heat-treating and sharpening operations have been completed. However, many custom-made blades and machine knives cannot be manufactured in this manner. Often, the best cutting edge configuration may be something other than a straight ground edge, or the preferred materials—high wear tool steels, carbide or ceramic, for example—are not available in strip form. Additionally, the blade shape and thickness may require that the blades be individually manufactured, since conventional strip sharpening is limited to essentially rectangular-shaped blades that do not exceed approximately .040" (1mm) thickness.

Specialty Blades' unique sharpening process combines the multiple step grinding and honing sequences of conventional razor blade technology with Computer Numerical Control (CNC) Technology. This union provides the flexibility to produce razor sharp edges on a wide variety of blade shapes and sizes within short lead times, while requiring minimal special tooling. CNC sharpening technology also ensures that cutting edges are consistently sharpened from blade to blade within a manufacturing lot, as well as from order to order.